

1/2 LITER DRAIN CANISTER w/AUTOMATIC DRAIN FLOAT

Drain Canisters primary function is to trap, remove and route liquids from both vacuum and compressed air systems.

Drain canisters are typically found between control or switching devices, to allow liquid to fall out or coalesce as liquid and gas passes through the drain canister. A mechanical float drain is used to route trapped liquids away as the accumulate in the bottom of the canister. Secondary benefits include, but are not limited to, increasing system volume. Increased system volume stabilizes many fluid power circuits, making them less volatile to system flow demands.

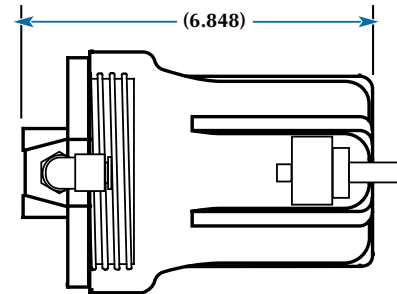
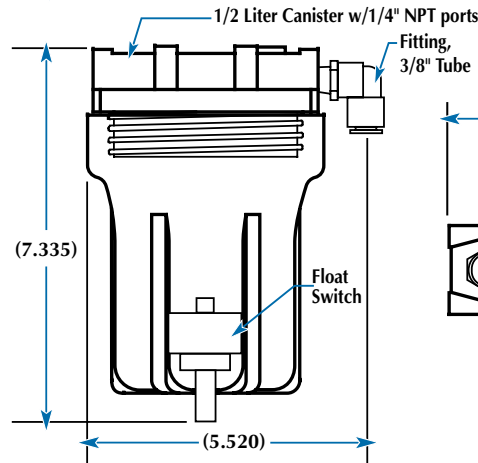
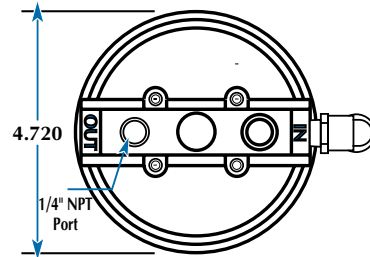

Part Number	Price
RIPIAPIDIFKQ2L11-35S	\$56.50

**POWER
AIR®**